

明泰科技 法人說明會

2021/3/22

投資安全聲明

本簡報及同時發佈之相關訊息內容，除簡報內之歷史資訊外，簡報事項係屬前瞻性說明。前瞻性說明受到風險及不確定性因素影響，可能造成公司實際業績及成果與前瞻性說明有顯著差異。這些風險及不確定性因素包括國際經濟狀況、市場需求變化、商業環境、上下游供應鏈、競爭行為、獲取和開發特殊項目的能力、資金運作能力、消費者變化、商業消費習慣、匯率波動、及其他各種本公司不能完全控制或根本不能控制的風險因素。

會議議程

1. 公司未來目標與展望
2. 2020年第四季暨年度財務報告
3. 公司營運與發展
4. 問答交流

公司未來目標
與展望



明泰科技贏的策略

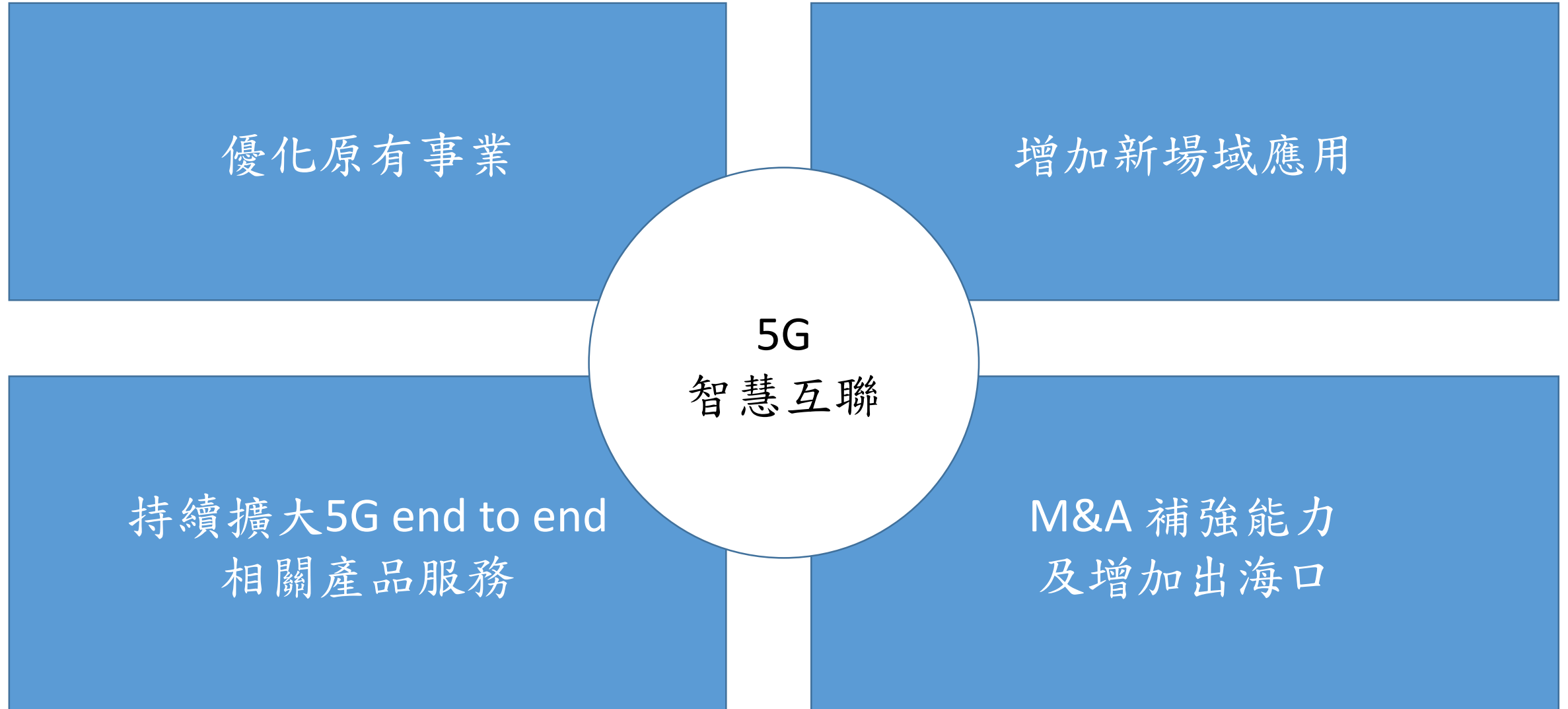

成長策略之具體實現

➤ 優化原有事業

- ✓ 提供企業、工業、資料中心以及電信用高階交換器
- ✓ 結合有線寬頻通路，提供無線寬頻等產品之差異化服務
- ✓ 持續強化數位多媒體產品力

➤ 持續擴大 5G end to end 相關產品服務

- ✓ 強化5G產品力
- ✓ 提供 end to end 相關產品

➤ 增加新場域應用

- ✓ 垂直市場
- ✓ 資料中心、電信網路、汽車電子等領域新應用

➤ M&A 補強能力及增加出海口

2020年第四季暨
年度財務報告



合併綜合損益表摘要 (Quarterly)

單位：新台幣百萬元

	4Q 2020		3Q 2020		QoQ	
	Amount	%	Amount	%	Amount	%
營業收入淨額	9,790	100.0	9,671	100.0	119	1.2
營業成本	8,353	85.3	8,213	84.9	140	1.7
營業毛利	1,437	14.7	1,458	15.1	(21)	(1.4)
營業費用	1,082	11.0	1,081	11.2	1	0.1
營業淨利	355	3.6	377	3.9	(22)	(5.8)
營業外(損)益	37	0.4	(51)	(0.5)	88	171.9
稅前淨利	392	4.0	326	3.4	66	20.1
本期淨利	315	3.2	264	2.7	51	19.5
歸屬母公司業主淨利	235	2.4	240	2.5	(5)	(2.2)
每股盈餘(元)	0.43		0.44			

合併綜合損益表摘要 (YTD)

單位：新台幣百萬元

	2020 ^(註)		2019		YoY	
	Amount	%	Amount	%	Amount	%
營業收入淨額	32,171	100.0	15,826	100.0	16,345	103.3
營業成本	27,164	84.4	13,212	83.5	13,952	105.6
營業毛利	5,007	15.6	2,614	16.5	2,393	91.5
營業費用	4,109	12.8	2,382	15.0	1,727	72.5
營業淨利(損)	898	2.8	232	1.5	666	286.7
營業外(損)益	22	0.1	108	0.6	(86)	(79.7)
稅前淨利(損)	920	2.9	340	2.1	580	170.6
本期淨利(損)	725	2.3	239	1.5	486	203.5
歸屬母公司業主淨利	557	1.7	239	1.5	318	133.1
每股盈餘(虧損)(元)	1.03		0.44			

(註) 本公司自2020/01/01起將仲琦科技及其子公司列入合併綜合損益表。

合併資產負債表摘要

單位：新台幣百萬元

	31-Dec-20		31-Dec-19		YoY	
	Amount	%	Amount	%	Amount	%
現金及約當現金	5,710	21.1	5,918	23.7	(208)	(3.5)
應收帳款	6,801	25.2	4,293	17.2	2,508	58.4
存貨	7,029	26.0	5,089	20.4	1,940	38.1
其他流動資產 ^(註)	1,167	4.4	3,849	15.4	(2,682)	(69.7)
非流動資產	6,299	23.3	5,851	23.3	448	7.7
資產總計	27,006	100.0	25,000	100.0	2,005	8.0
流動負債	13,716	50.8	9,585	38.4	4,130	43.1
非流動負債	552	2.1	1,368	5.5	(816)	(59.6)
負債總計	14,268	52.8	10,953	43.9	3,314	30.3
股本	5,417	20.1	5,426	21.7	(9)	(0.2)
歸屬母公司股東權益	9,704	35.9	9,981	39.9	(277)	(2.8)
非控制權益	3,034	11.2	4,066	16.2	(1,032)	(25.4)

(註) 其他流動資產包含原始到期日超過三個月之銀行定期存單：2020/12/31 NT\$139M；2019/12/31 NT\$1,054M

營收比重 (YTD) _ 產品別

2020

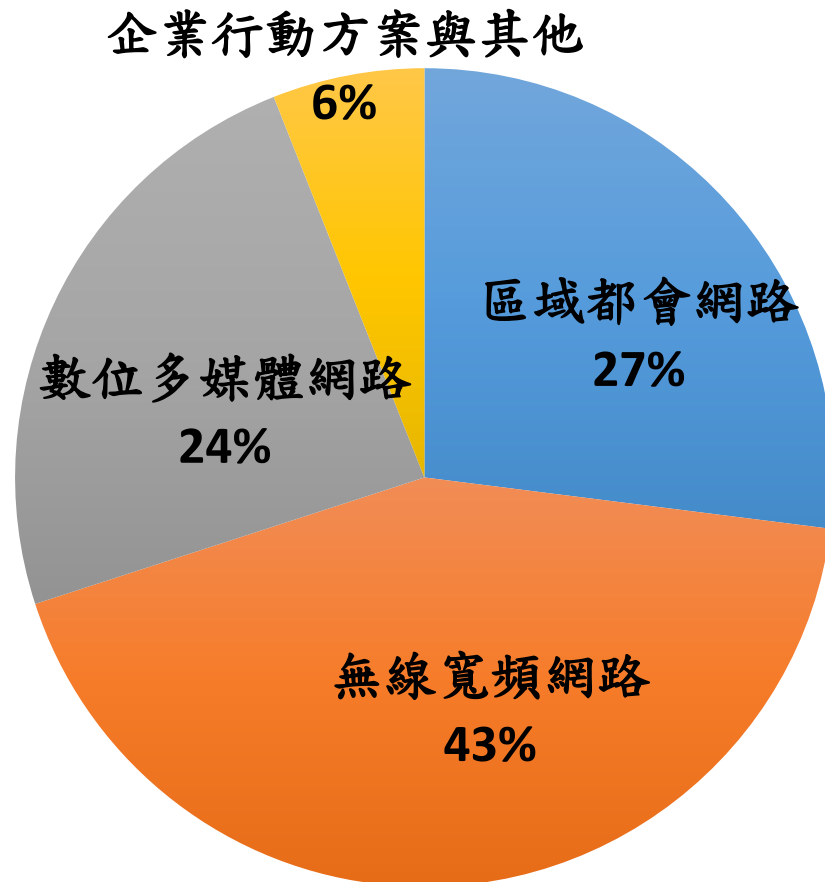

2019

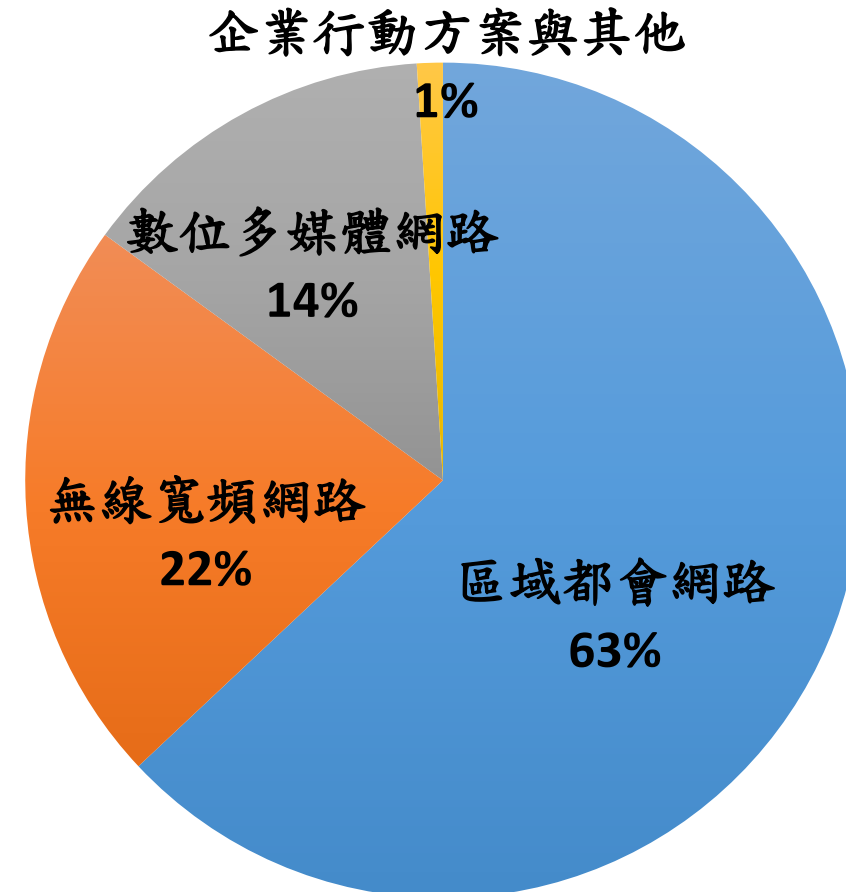

營收比重 (YTD) _ 區域別

2020

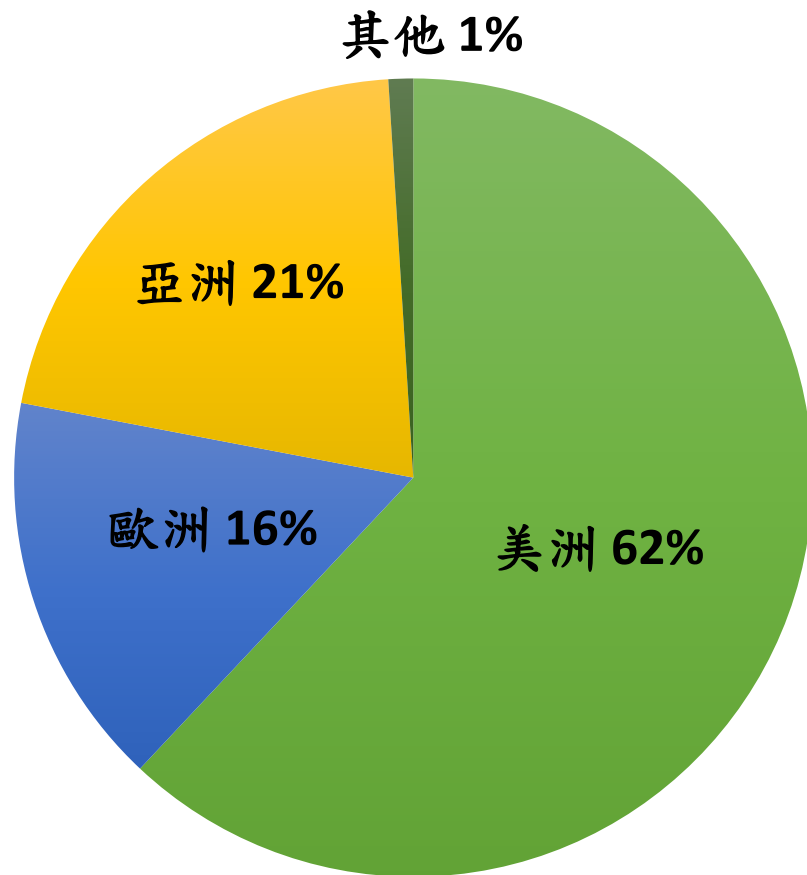

2019

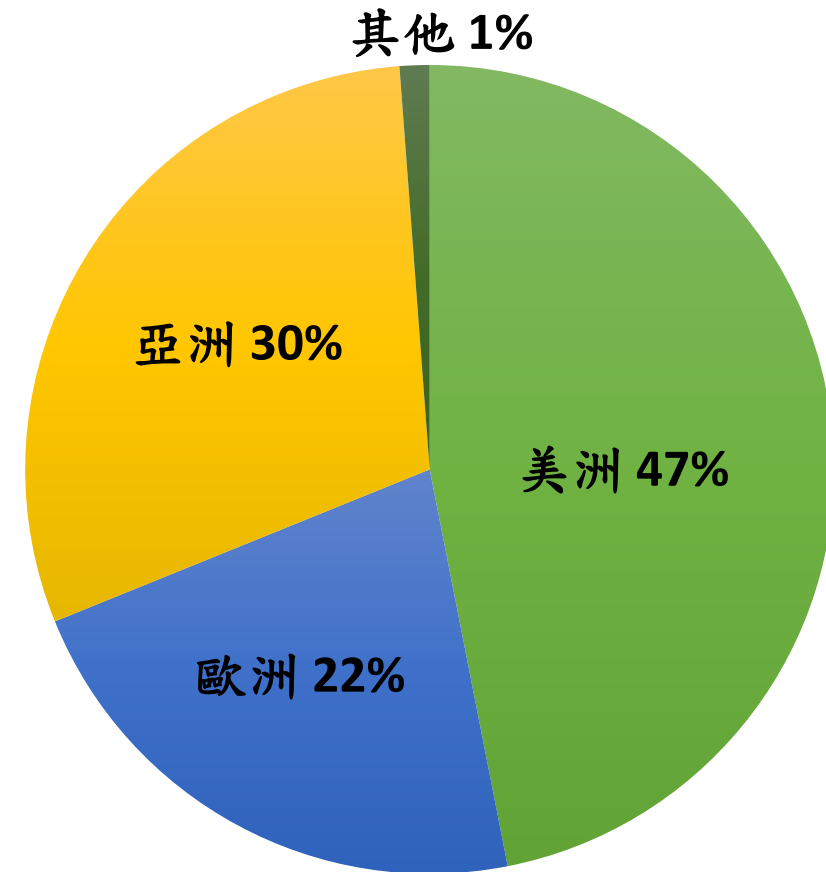

公司營運與發展





明泰科技成長動能

- 事業體 優質產品持續穩健成長
- 垂直市場 天羅地網 神機妙算



事業體 優質產品持續穩健成長

LAN/MAN BU - Product Portfolio

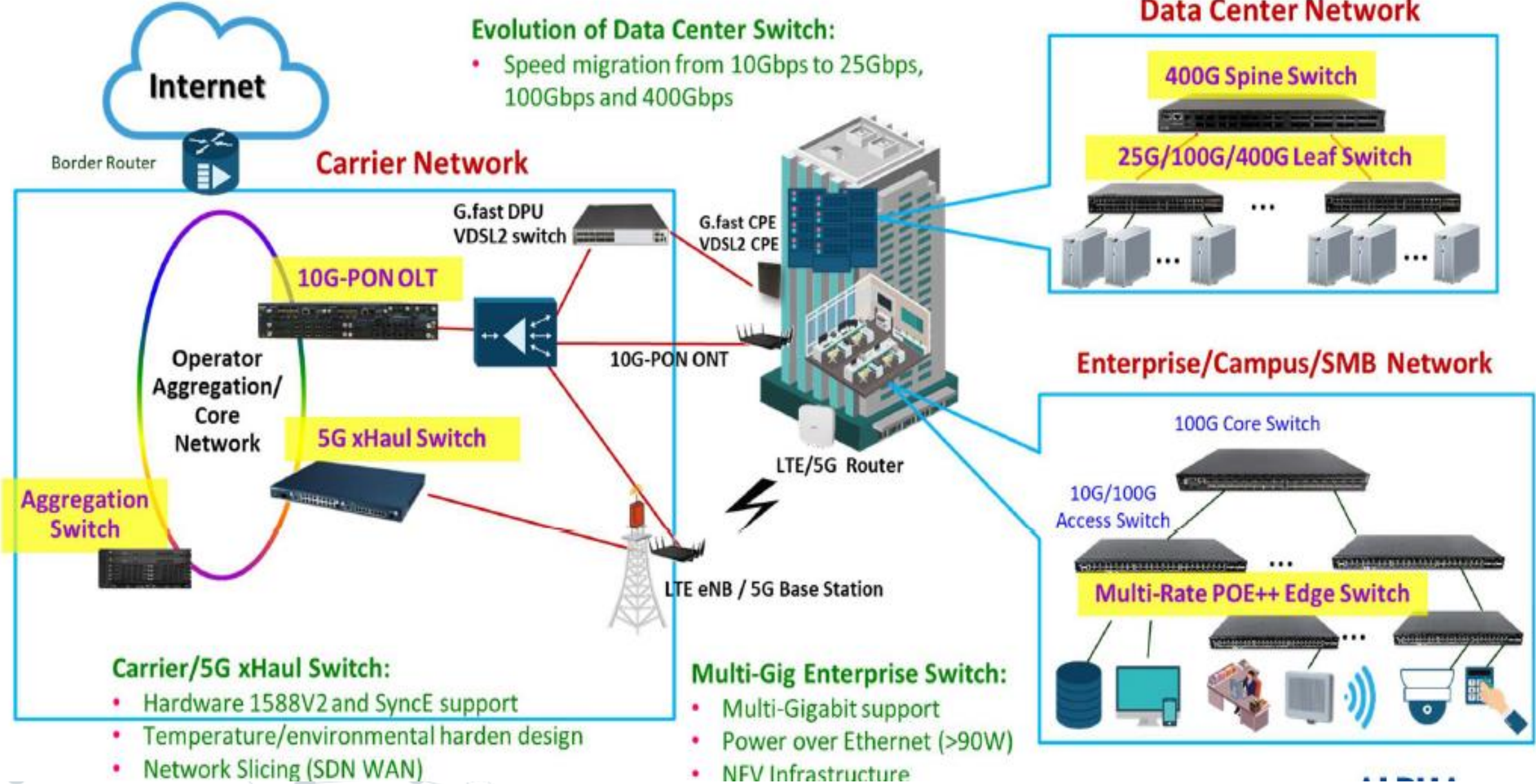

WB BU -5G End-to-End Total Solution

ALPHA Networks

5G Enterprise Network

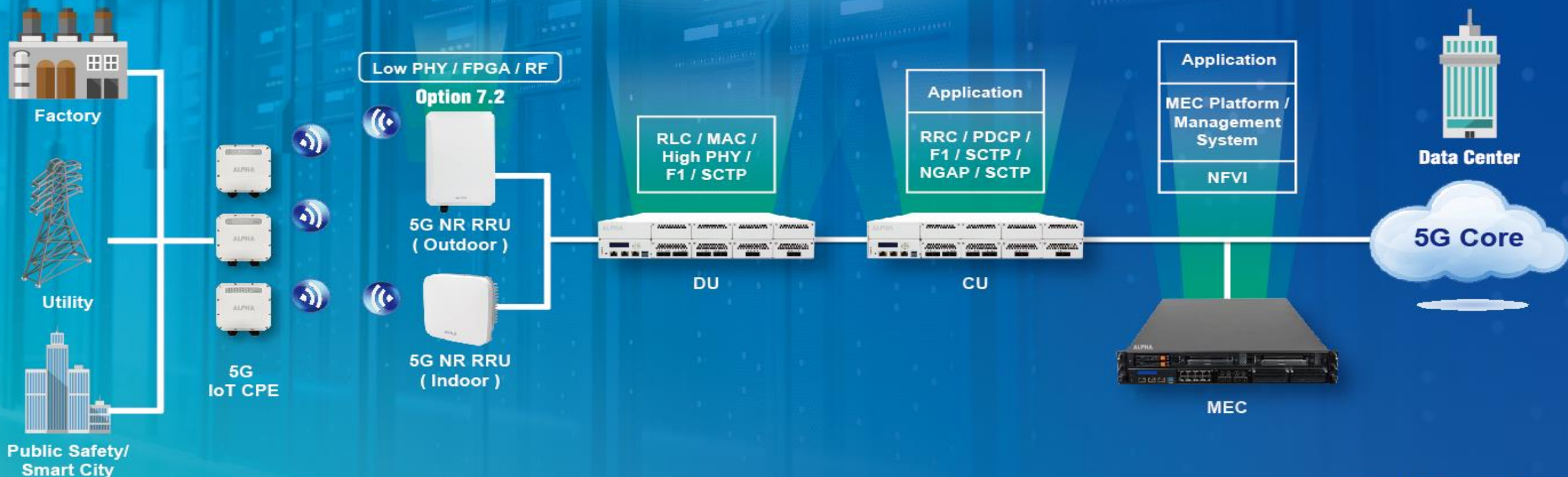

WB BU-FWA & 5G IoT GW Products

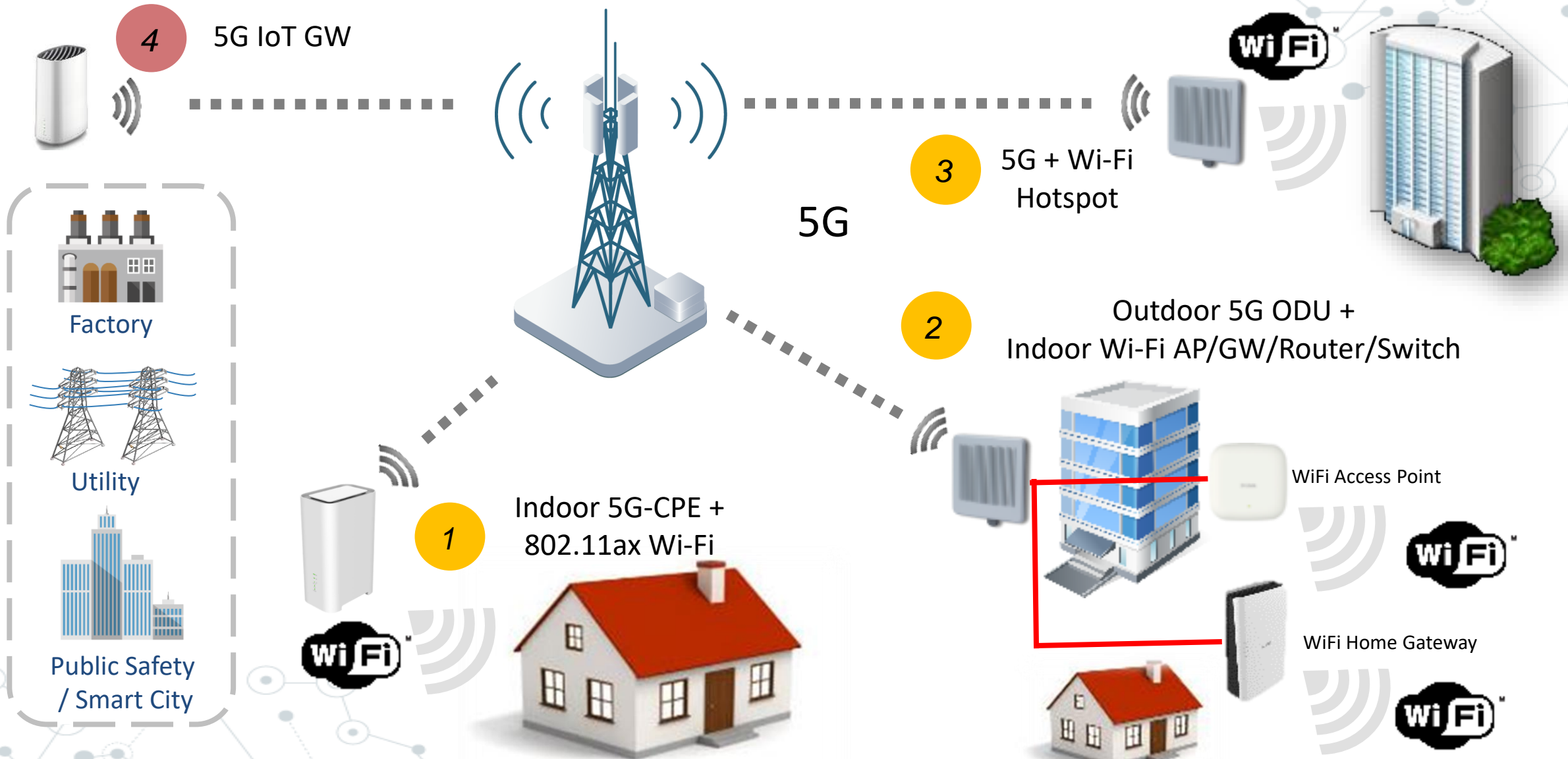

WB BU-XGSPON Product Portfolio



SFP+

- 1x SC/APC 10G Uplink
- IEEE1588v2

SFU

- 1x SC/APC 10G Uplink
- 1x 10G LAN
- 1x XFS port

ONU

- 1x SC/APC 10G Uplink
- 1x 10G LAN
- 4x 1G LAN

HGU

- 11ax 4x4 Dual band Wi-Fi
- 1x SC/APC 10G Uplink
- 1x 2.5G LAN
- 4x 1G LAN
- 2x FXS ports

WB BU-Wi-Fi Mesh

Traditional Standalone Router

- Wi-Fi Signal Coverage is Limited



Whole Home Coverage

- Qualcomm Proprietary MESH
- EasyMESH R.1



DM BU-Product Portfolio

Video Surveillance

- Fixed Dome Camera
- Panoramic Camera
- Bullet Camera
- Industrial Camera
- Network Video recorder
- Doorbell Camera
- Outdoor Battery Camera
- Indoor Camera
- Fisheye Camera
- PT Camera

IoT (Smart Home)

- Z-WAVE Gateway & Sensors



MES BU-Radar Products

RF Sensors and Accessories

- 24 / 77 / 79 GHz Intelligent Radar
- AVM System
- Radar + Image Fusion
- TBOX

Automotive Applications

- Collision Warning
- Blind Spot Detection
- Parking Assistance
- Sensor Fusion

Industrial Application

- Smart City
- Smart Auto Assembly Line
- Unmanned Aircraft System
- Smart Building Automation



MES BU-Applications

AVM Image and Radars
(Shipping)



BUS Blind-View Warning
(Field Trial)



Transportation ADAS
(Field Trial)



Motorcycle Rear Warning
(Field Trial)



Passenger Car BSD/LCA/RCTA
(Shipping)



24GHz/77GHz/79GHz Radar

Smart Parking Sensor
(Shipping)



TP BU-MEC Solution

ALPHA's 5G / 4G Edge Computing Solution

- ALPHA's MEC Edge platform is designed to operate as a solution:
 - Service-based Architecture Private Cloud: Compute, Storage, and Networking
 - Micro-service: IPC Server + MEC NFV Software + Edge-to-Core Networking
 - To ensure security and transmit data latency in less than a few milliseconds

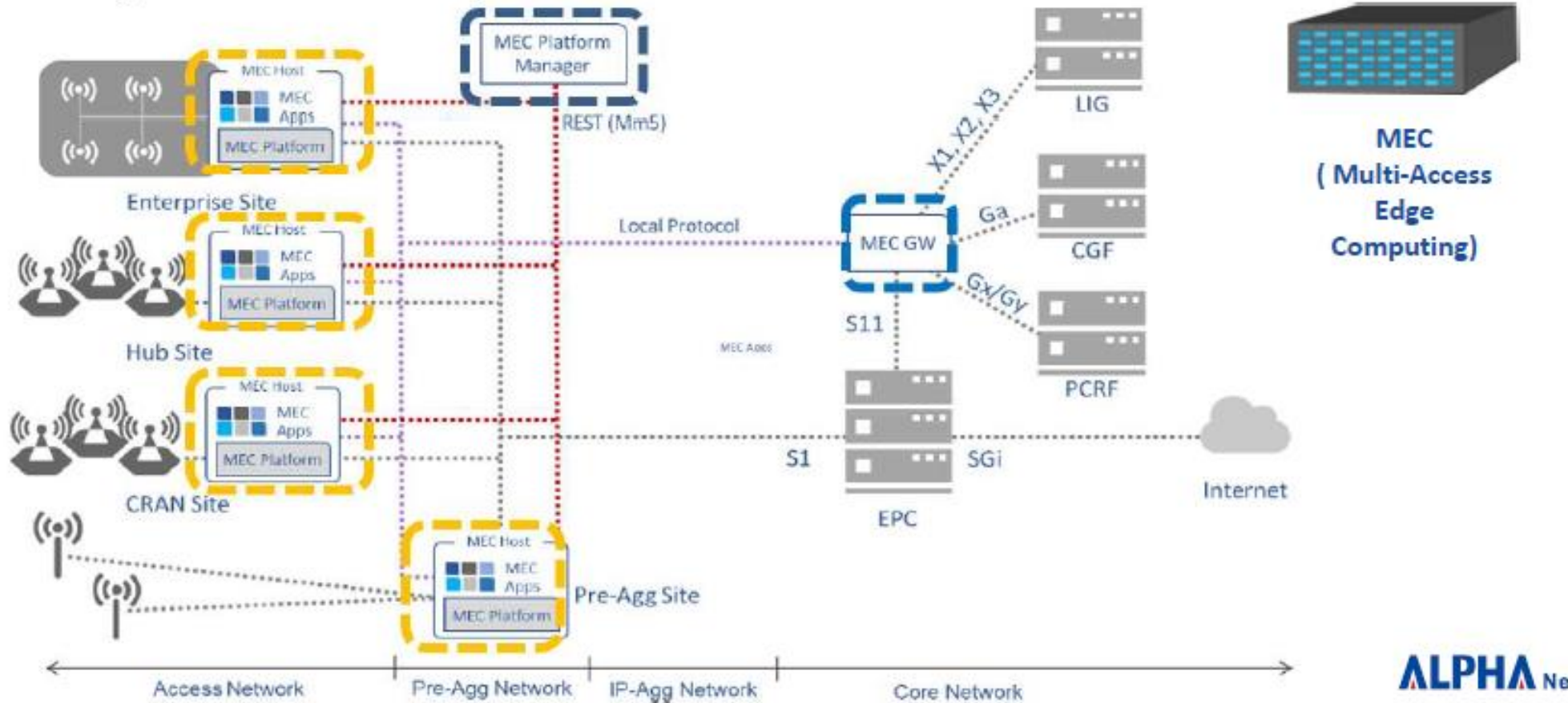



垂直市場 天羅地網 神機妙算

全球主要關鍵技術正在快速收斂

滿足**高頻寬**、**低延遲**、**廣覆蓋**是最重要的議題

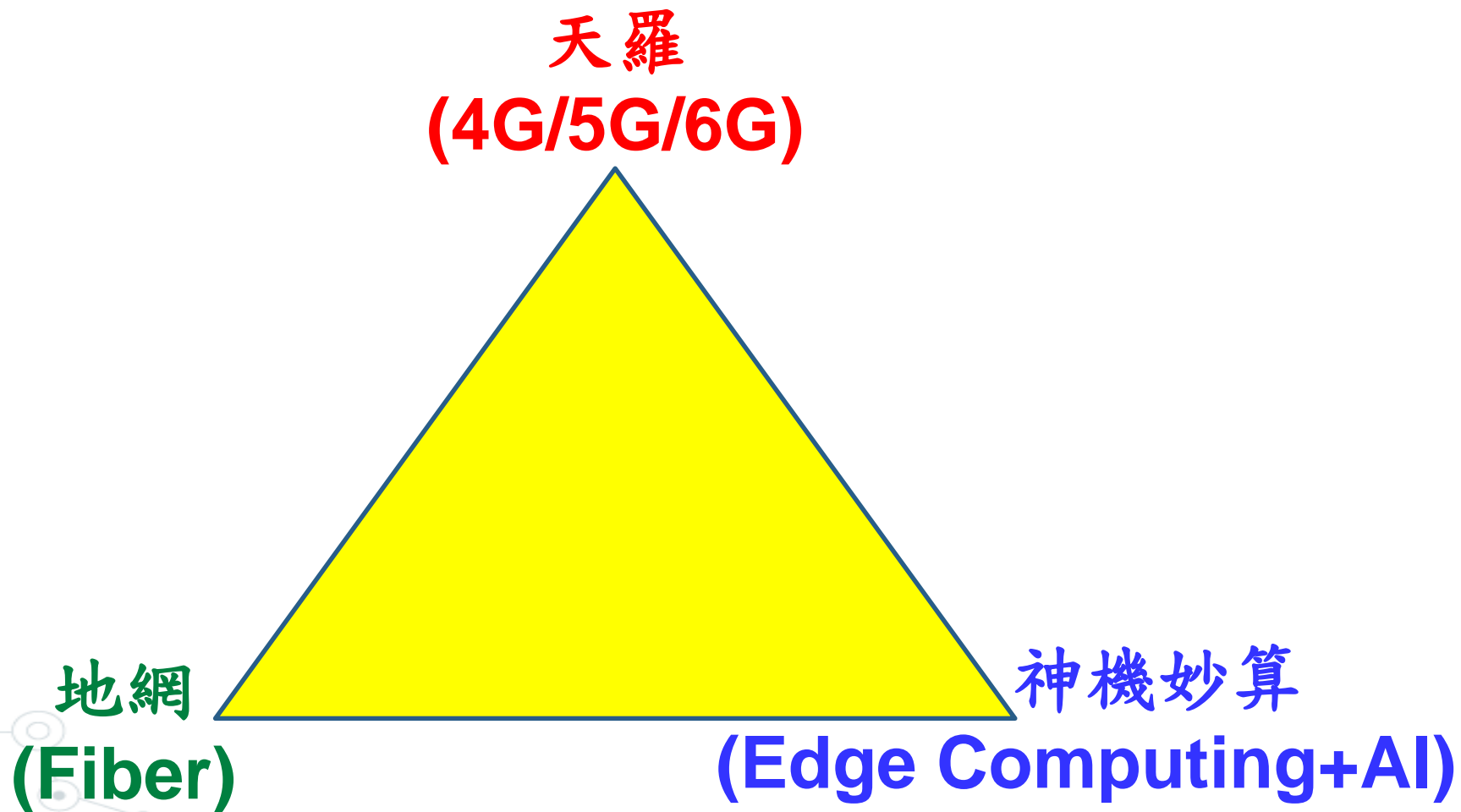

三大關鍵技術撐起四大應用

智慧製造

智慧醫療

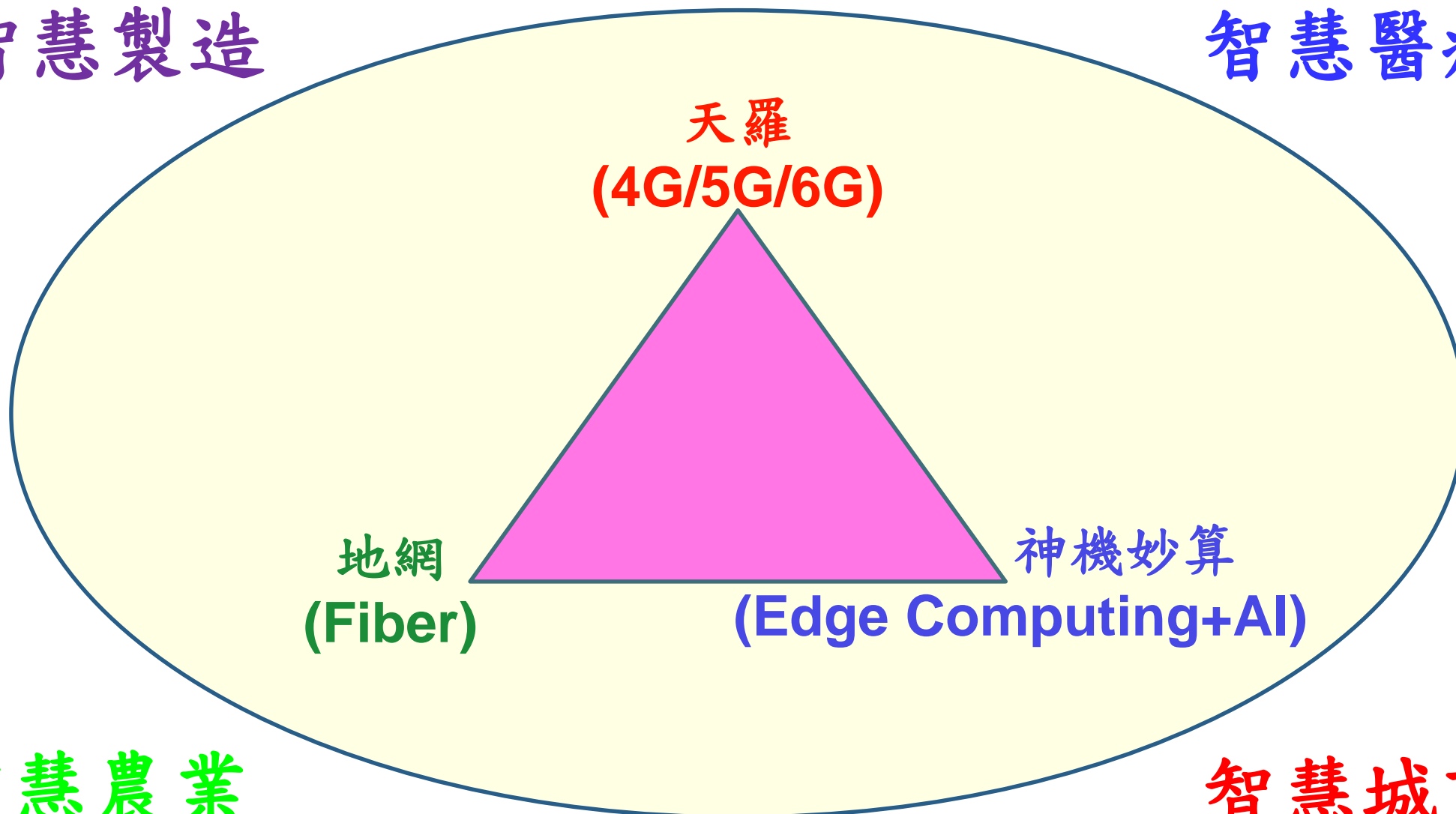

天羅
(4G/5G/6G)













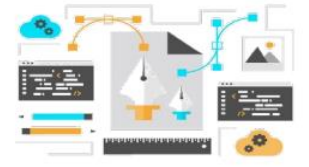































地網
(Fiber)

神機妙算
(Edge Computing+AI)

智慧農業

智慧城市

IT + CT + OT 架構整合

IT + CT 層 ACE PILLAR AIOT	智慧化	資料分析系統優化   智慧雲端應用 (分析與決策)	<ul style="list-style-type: none"> 智慧BI戰情室 智慧環安管理 (SESM) 智慧節能管理 智慧維運管理 智慧虛擬工廠 				
	自動化	製造管理(EMS) 工業電腦 ICT軟體	  	<ul style="list-style-type: none"> 智慧倉儲系統(Smart WMS)/智慧補發料系統 智慧無人搬運(Smart AGV)/智慧調度系統 智慧自動化生產線 物聯網雲端管理軟體IoT star 			
	資訊化	網路通訊 Enabling Connectivity	     	<ul style="list-style-type: none"> 製造執行系統 (MES) 5G企業專網 智慧聯網監控設備(SCADA) 工業物聯網智能控制器(WISE) 智能製造IIOT Gateway 解決方案 			
OT 層 系統架構	智能感測/控制器	    	<ul style="list-style-type: none"> 設備預知保養數據採集裝置(IWSN) 智慧電錶電力監控模組(PMMS) 智能樓宇水電空調監控裝置 工廠環安衛監控模組 PLC,人機介面,PLC/PC Based 運動控制器 機器視覺系統/ 機器人控制器 				
	自動化	系統設備元件	              	<ul style="list-style-type: none"> 機器手臂/AGV/AMR 自動化專用機及設備 變頻器 伺服驅動系統: 伺服驅動器, 馬達 減速機/滾珠軸承 滾珠螺桿/ 線性滑動/線性模組 線性滑台/ 電動缸 氣壓缸/ 電磁閥/ 流體控制閥 充電箱/工業電源 			

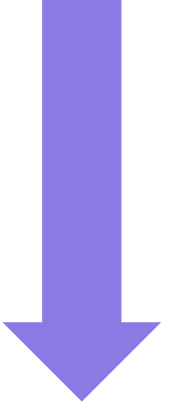
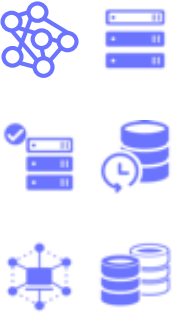
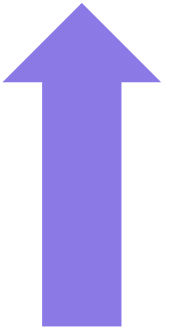

IT + CT + OT 架構整合

智慧製造

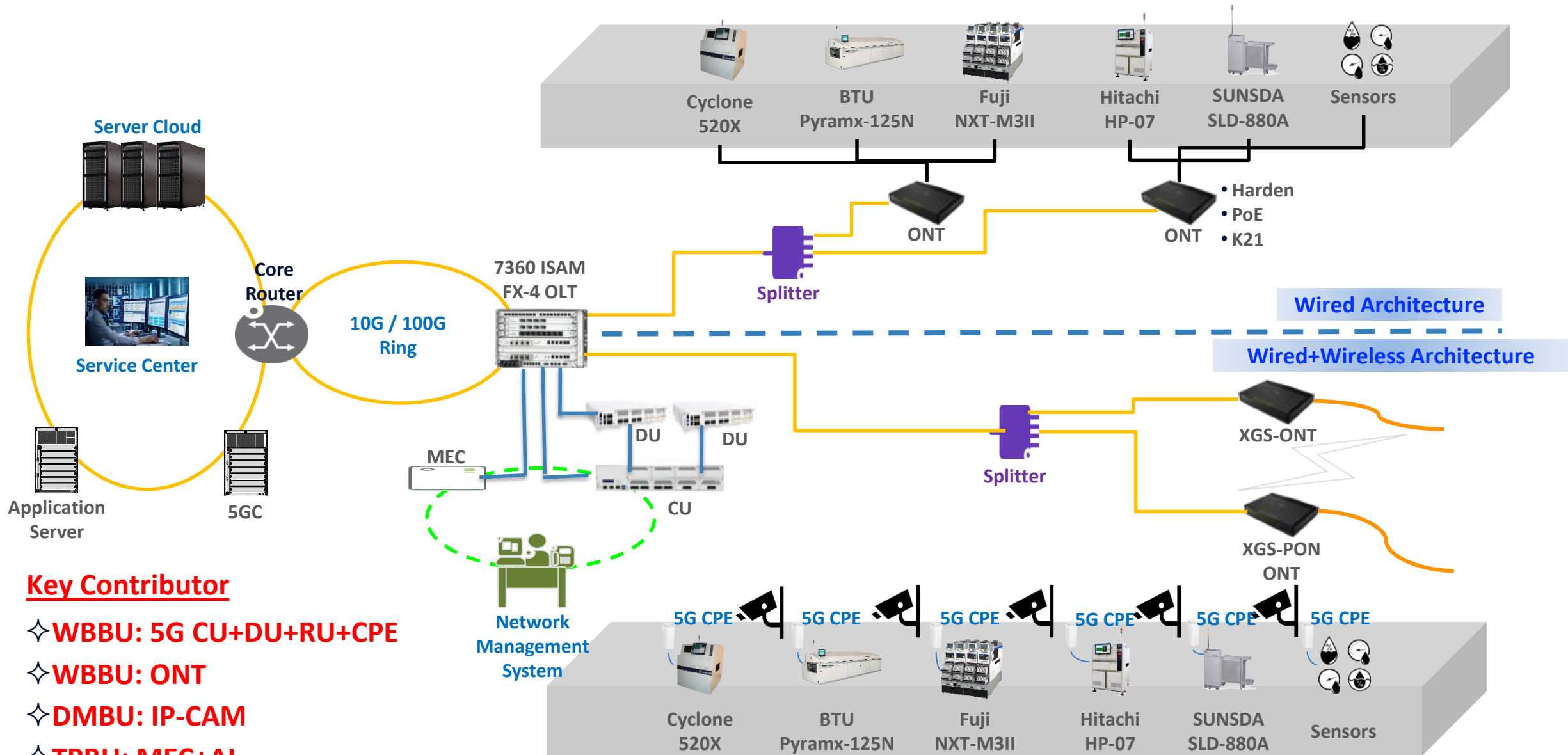

Key Contributor

- ✧ WBBU: 5G CU+DU+RU+CPE
- ✧ WBBU: ONT
- ✧ DMBU: IP-CAM
- ✧ TPBU: MEC+AI
- ✧ LAN/MAN BU: OLT & Switch

智慧醫療

Key Contributor

- ✧ WBBU: 5G CU+DU+RU+CPE
- ✧ DMBU: IP-CAM
- ✧ TPBU: MEC+AI
- ✧ LAN/MAN BU: Switch

醫聯網AI整合技術 嬰兒照護應用

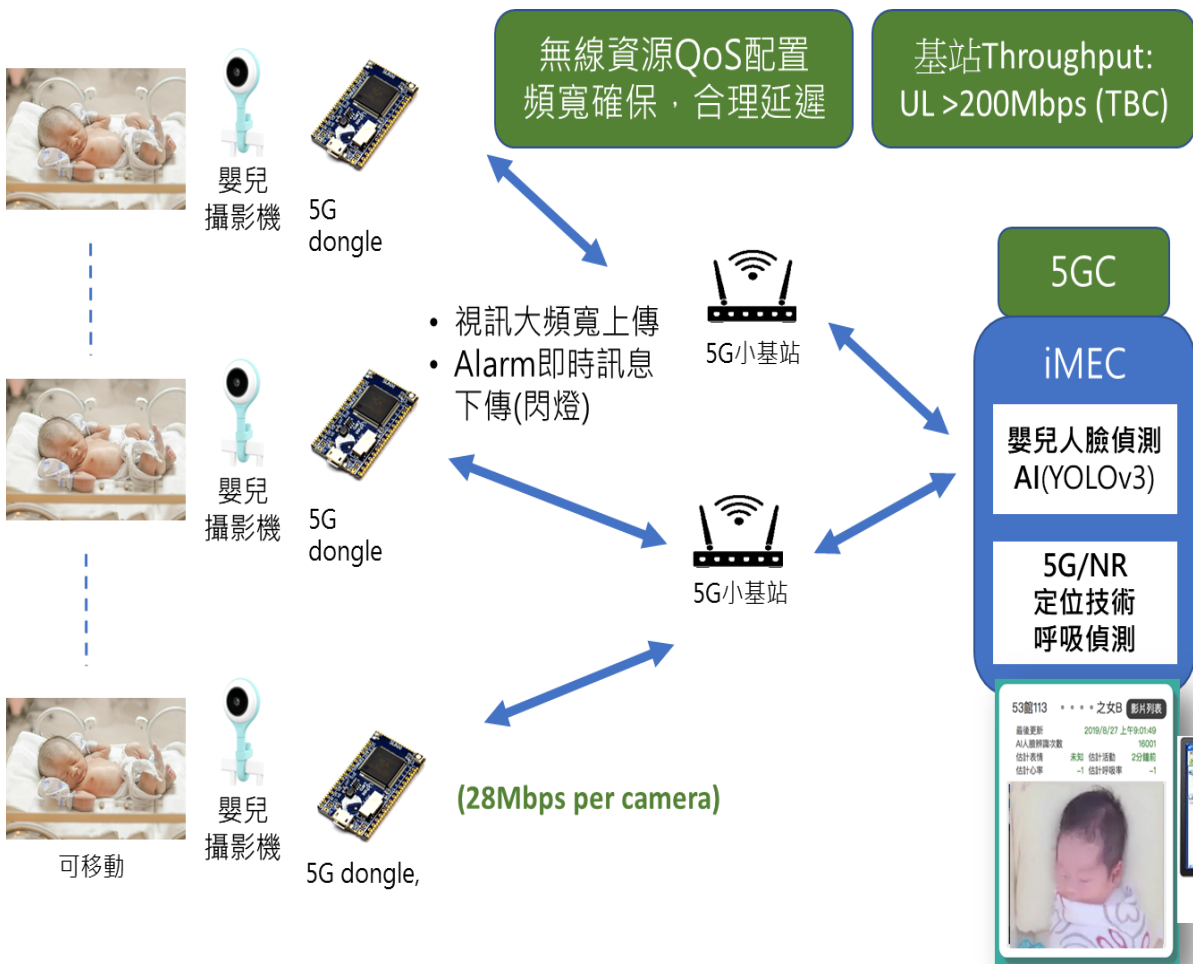

5F 佈纜線路平面圖

架設 RU 六台 (RU1-RU6)
架設 5G CPE 兩台

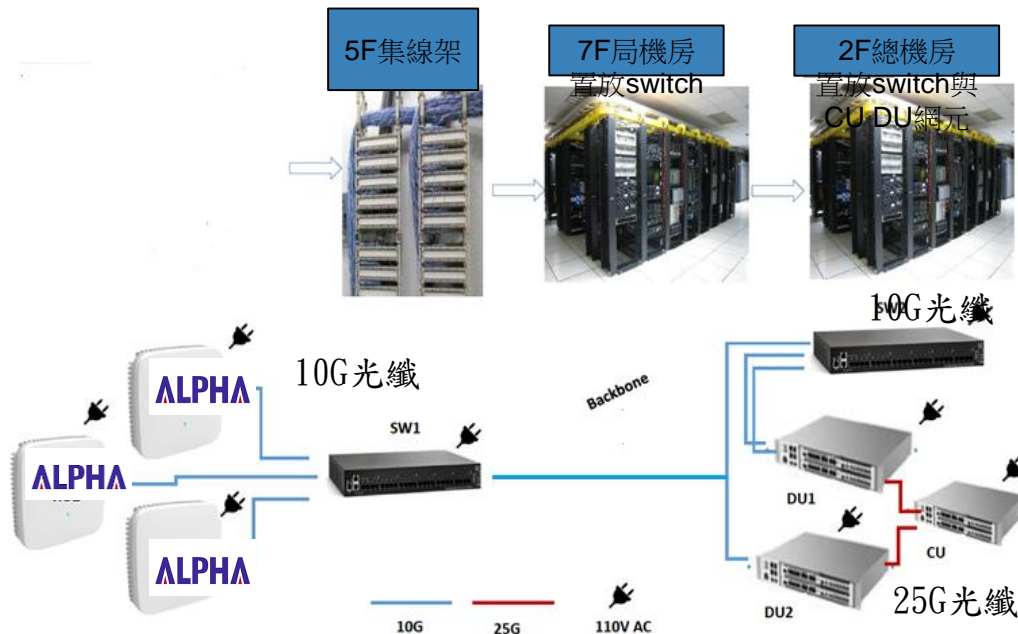
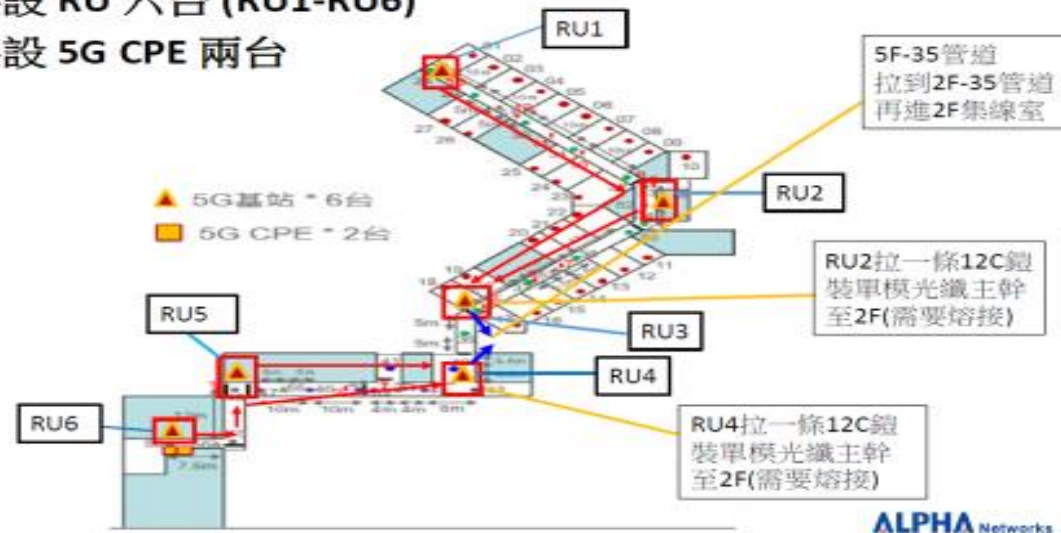

智慧農業



Temperature & Moisture Detection

Key Contributor

✧ WBBU: 5G CU+DU+RU

✧ WBBU: 5G CPE

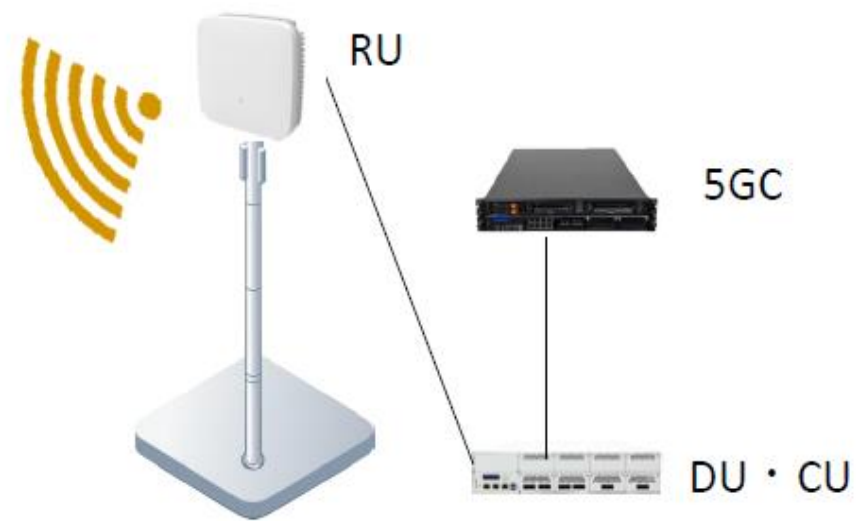

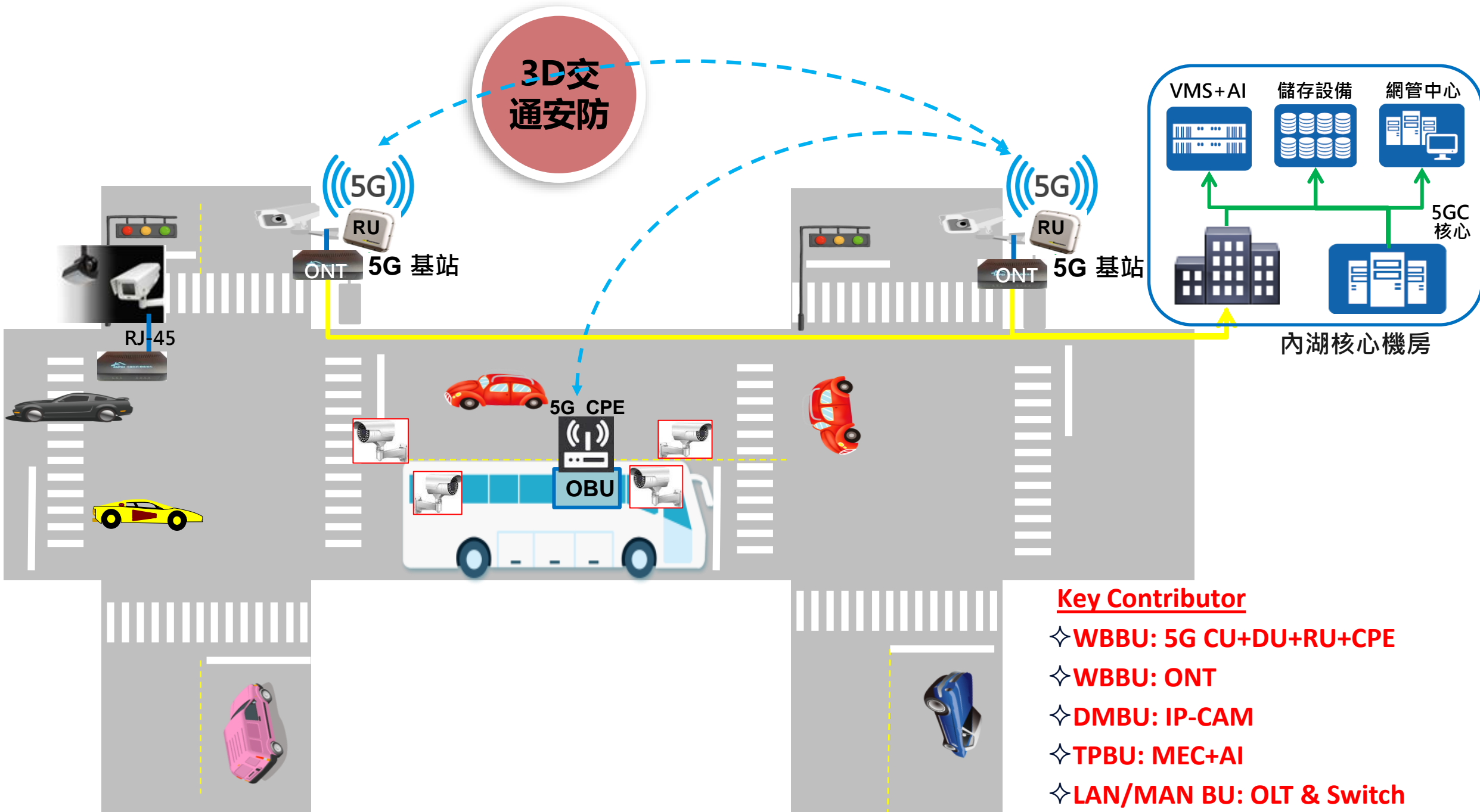

3D交通安防



Key Contributor

- ✧ WBBU: 5G CU+DU+RU+CPE
- ✧ WBBU: ONT
- ✧ DMBU: IP-CAM
- ✧ TPBU: MEC+AI
- ✧ LAN/MAN BU: OLT & Switch



謝謝

問答交流



THANK YOU

copyright ©2021 Alpha Networks Inc. All rights reserved